



190 WILDCAT ROAD, NORTH YORK, ONTARIO.CANADA M3J2N5
Tel:416-850-6427 Toll free: 1-877-52-FLOOR Fax:416-981-7799
www.heavenly-heat.com

Snow Melting Systems

INSTALLATION MANUAL

Please read through these instructions carefully before you begin installing & check that you are aware of all the components required.

Contents

1.0	Important Instructions before Installing the System	3
2.0	Calculations of Centre Spacing	4
3.0	Installation Instructions for Snow Melting System	
3.1	Control of Snow Melting System	5
3.2	Electrical Provisions for the System	5
3.3	Installation under Asphalt	6
3.4	Installation under concrete	7
3.5	Installation Instruction for Mat Configuration System	8
4.0	Warranty	9
5.0	Control Card	9

1.0 IMPORTANT INSTRUCTIONS PRIOR TO INSTALLATION

1. **Heating cable must not cross or overlap itself** at any point. This could cause the cable to overheat.
2. The **heating cable length should not be cut or altered** in any circumstances. This may cause over heating and resulting in damage to the cable.
3. The cold lead can be cut /extended to suit the location of the electrical power connection box.
4. **Take precautions to avoid damage to heating cable** during installation.
5. **Do not install the Heating cable below -15⁰C temperature.**
6. **Minimum bending radius** of the heating cable while laying shall not be less than 10 times of its diameter.
7. Twin conductor Heating Cable has an earth screen (metal sheath) to be connected to **earth** station and 2 wires, which are the **live & neutral** to be connected to the main supply.
8. Single conductor Heating Cable has an earth screen (metal sheath) and one connection lead wire each on both sides. Earth screen on both sides to be connected to **earth** station and 2 connection lead wires (one each on both sides) shall be connected to the **live & neutral** of the main supply.
9. **Check the main voltage and wattage** of the heating cable is as per the selection made. These are marked on the packing box of the product. A certified electrician should connect the Heating System.
10. **Check the continuity, resistance and insulation resistance** of the Heating Cable before installing and also after installing. Resistance value shall match to the value given in product range table. A tolerance of -5% to +10% is allowed. Insulation Resistance shall be more than 10 Mohms.
11. Keep the power cable conduit separate from the sensor cable conduit.
12. Allow sufficient drying or curing period of the slab / concrete / asphalt after installing the heating system and then energize the heating system.
13. For easy reference, fix a label at power distribution board indicating the location of the heating units installed.

WARNING

1. **The cable must not be shortened or cut in any manner or subjected to strain at the splice joint.**
2. **Connecting the cable to the joints should be undertaken by certified electrician only.**

2.0 CALCULATION OF CENTRE SPACING:

In order to fit the cable properly in designated space, it is necessary to determine the spacing between the Cable (On Centre spacing or OC.). By using the below mentioned formula, you can calculate the OC in inches.

$$\frac{\text{Net Heating Area} \times 12}{\text{Length of Cable(s) in feet}}$$

Each cable's length is listed in the product selection guide (Annexure – I); combine the cable lengths if more than one is being used. Once you have your O.C. spacing calculated you are ready to begin laying out your cable. The formula assumes that you will use ½ O.C. spacing around walls and fixed objects and full O.C. spacing between cable runs. It is recommended that you cut a measuring template out of cardboard representing the O.C. spacing less the thickness of the cable. You will then be able to place this template next to a cable in order to determine where the next run should be placed. Fold the template in half to determine the ½ O.C. spacing to be used around walls and fixtures.

3.0 INSTALLATION INSTRUCTIONS

3.1 CONTROL OF SNOW MELTING SYSTEM

A control suitable for Snow Melting system with pavement mounted sensor should be used for Snow Melting Application.

The floor sensor location shall be in open area, away from trees or bushes so that it can sense moisture in the air / snow fall and initiate the energisation of heating cable.

3.2 ELECTRICAL PROVISIONS FOR THE SYSTEM

The Snow Melting system installation wiring shall be in accordance with the national wiring rules.

The Snow / moisture sensor cable and the heating cable cold leads shall be routed to the power connection box in a separate conduit.

In case the Snow Melting system load is more than the thermostat power rating, connect the system as per the diagram below.

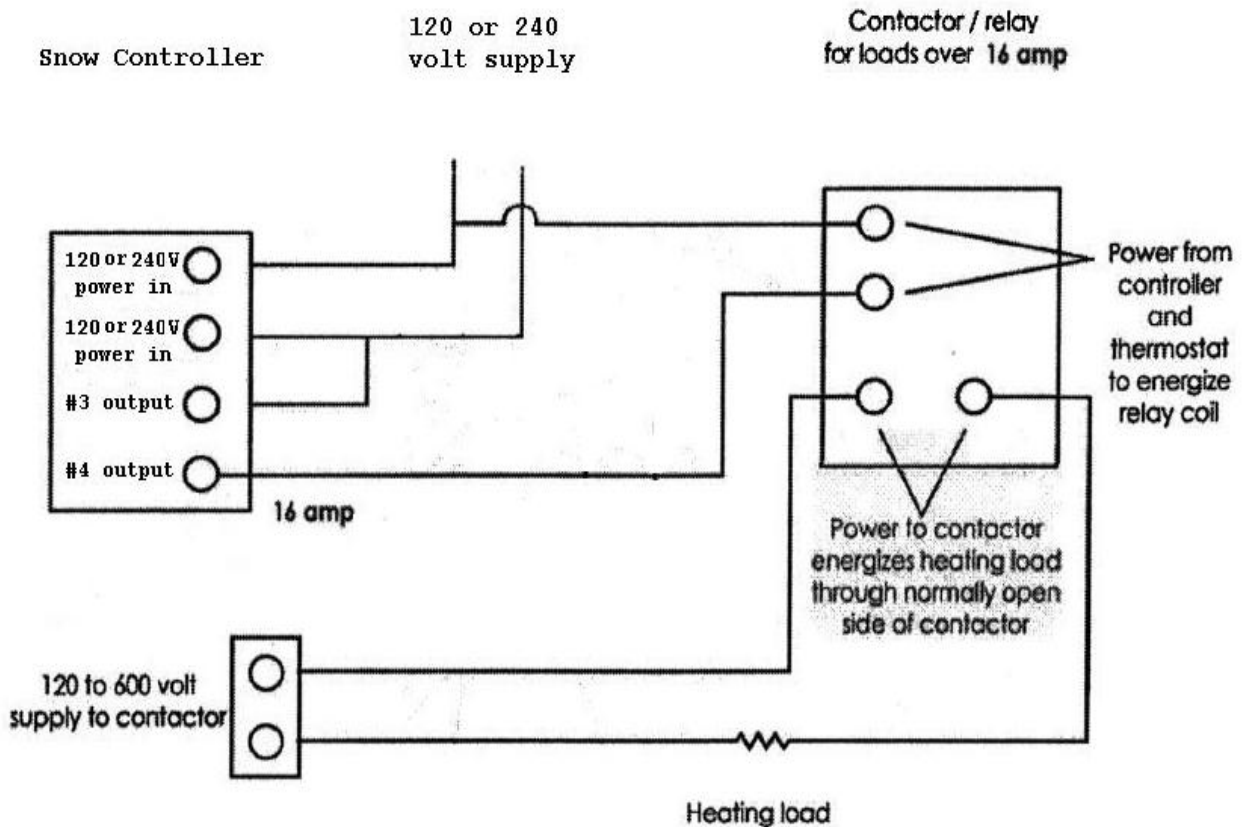

3.3 INSTALLATION UNDER ASPHALT

1. Clean the area below the heating cable so that it is free from sharp objects.
2. Take the cold lead of the Cable through conduit pipe into the junction box.
Do not use excessive forces to pull the cold leads otherwise it may damage the hot-cold splice.
3. Lay the cables according to the plan and apply a coat of bituminous binder.
4. Before the asphalt is applied, a thin layer of sand or concrete $\frac{3}{4}$ " – 1" (20 mm) thick should be used to cover the top of the cables to protect them from the heat of the asphalt.
5. Allow the asphalt to cool to a temperature of 130 to 140 deg C before it is applied. The Cables can stand this temperature for a limited period.
6. Position the snow sensor in the open area, away from trees or bushes so that it can sense the moisture in the air / snow fall and initiate the heating of the cables. The sensor cables must be protected by a suitable conduit pipe. The conduit pipe is sealed at the end so the asphalt cannot leak in.
7. The cold leads should be protected by a suitable conduit pipe and its ends sealed so that Asphalt does not leak in.
8. The asphalt should have a minimum thickness of 2" (50 mm) measured from the top of the snow melting cable.
9. After the asphalt gets hardened, complete all the required connections (Snow sensor, thermostat etc) before switching on the heating Cables.
10. For easy reference, fix a label at power distribution board, indicating the location of the heating cables. An Electrician should measure the cable resistance and Insulation resistance before commencing installation, before applying asphalt and after the asphalt is applied and record the readings on Control Card provided at the end of this manual.

3.4 INSTALLATION UNDER CONCRETE

1. Clean the area below the heating cable so that it is free from any sharp objects.
2. Take the cold lead of the Cable through conduit pipes into the junction box.
Do not use excess forces to pull the cold leads otherwise it may damage the hot-cold splice.
3. Lay the Cables according to the plan and fasten them to the reinforcing rods so that they do not move during concrete pouring.
4. The concrete mixture must not contain sharp stones as these may damage the cables.
5. Pour the concrete covering the cables completely without leaving any air pockets.
6. Allow the concrete to set for 30 days before the heating system is turned ON.
7. Position the snow sensor in the open area, away from trees or bushes so that it can sense the moisture in the air / snow fall and initiate the heating of the cables. The sensor cables must be protected by a suitable conduit pipe. The conduit pipe is sealed at the end so the concrete does not leak in.
8. The cold leads should be protected by a suitable conduit pipe and its ends sealed so that concrete does not leak in.
9. The concrete should have a minimum thickness of 2” (50 mm) measured from the top of the snow melting cable.
10. For easy reference, fix a label at power distribution board, indicating the location of the heating cables.
11. An Electrician should measure the cable resistance and Insulation resistance before commencing installation, before pouring of concrete and after the concrete is poured and record the readings on Control Card provided at the end of this manual.
12. For easy reference, fix a label at power distribution board indicating the location of the heating units installed for future reference

3.5 INSTALLATION INSTRUCTION FOR MAT CONFIGURATION SYSTEM

1. Installation procedure for heating cables – Mat Configuration, is similar to the Cables except that in case of mats, laying and fastening to the reinforced rods is not necessary.
2. You can simply unroll the mat on prepared surface before pouring Asphalt or Concrete.
3. Mat can be cut and turned at 90° or 180° (as shown below) while laying it to cover the total area (heating cable should not be cut).

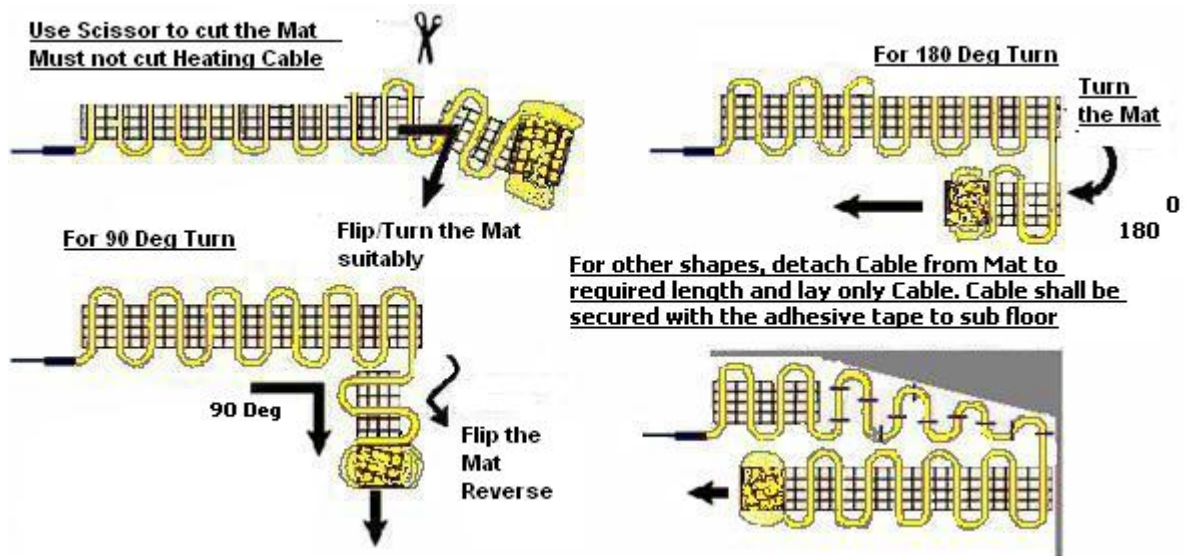

Measure & plan the area to be heated by heating cables for snow melting application, allowing for obstructions such as light poles, columns and drains. If you desire complete snow removal, select heating cables to cover the entire area.

4.0 WARRANTY

Heavenly Heat Inc. provides a warranty for EasySnowMelt for a period of 10 years from date of purchase, for the material and workmanship under normal operating conditions.

In case of defective material, Heavenly Heat's obligation will be limited to repair or supply a new material, free of charge to the customer.

The warranty does not cover installations made by unauthorized persons or faults caused by incorrect design by others / misuse / damage caused by others / damage in transit / incorrect installation and any other subsequent damage that may occur. Repair / replacement will be fully chargeable if the damage is because of any of the above reasons.

Heavenly Heat Inc. is under no circumstances liable for any consequential damages or losses including without limitations the loss or profit arising from any cause whatsoever.

The guarantee is a material warranty only and does not cover field labor.

The warranty is void if there is any payment default and if data is not filled on attached Control Card.

5.0 CONTROL CARD

Cat Ref & Sl. No.	Test	Before commencing of Installation	After Installation but before final flooring	After final Flooring
	Continuity			
	Resistance of Cable (Ohms)			
	Insulation Resistance (M Ohms.)			

Address of Installation :

Date of Installation :

Name & Signature of Qualified Electrician :

Note: Ensure this control card is filled & signed by certified electrician and safely stored along with your floor plan.